



Floor Fryers

12/2014

Models: FF300, FF400, FF518

Please read and keep these instructions. Indoor use only.

SAFETY PRECAUTIONS

Before installing and operating this equipment, be sure everyone involved in its operation is fully trained and aware of precautions. Accidents and problems can be caused by failure to follow fundamental rules and precautions.

The following symbols, found throughout this manual, alert you to potentially dangerous conditions to the operator, service personnel, or to the equipment.



This symbol warns of immediate hazards that will result in severe injury or death.



This symbol refers to a potential hazard or unsafe practice that could result in injury or death.



This symbol refers to a potential hazard or unsafe practice that could result in injury, product damage or property damage.



This symbol refers to information that needs special attention or must be fully understood, even though not dangerous.



WARNING
FIRE HAZARD
FOR YOUR SAFETY

Do not store or use gasoline or other flammable vapors and liquids in the vicinity of this or any other appliance. Keep area around appliances free and clear of combustibles.

Purchaser of equipment must post in a prominent location, detailed instructions to be followed in the event the operator smells gas. Obtain the instructions from the local gas supplier.



WARNING
BURN HAZARD

Contact with hot oil will cause severe burns. Always use caution. Oil at 200°F is more dangerous than boiling water.



WARNING

In the event a gas odor is detected, shut down equipment at the combination gas valve and contact the local gas company or gas supplier for service.

NOTICE

Avantco Floor Fryers are intended for commercial use only. Not for household use.

Warranty will be void if service work is performed by other than a qualified technician, or if other than genuine Avantco replacement parts are installed.

Be sure this Operator's Manual and important papers are given to the proper authority to retain for future reference.

Congratulations! You have purchased one of the finest pieces of commercial cooking equipment on the market.

You will find that your new equipment, like all Avantco equipments, has been designed and manufactured to meet the toughest standards in the industry. Each piece of Avantco equipment is carefully engineered and designs are verified through laboratory tests and field installations. With proper care and field maintenance, you will experience years of reliable, trouble-free operation. **For best results, read this manual carefully.**

RETAIN THIS MANUAL FOR FUTURE REFERENCE.

MODELS

This manual is for Avantco Fryers with 35-pound FF300, 55-pound FF400, or 85-pound FF518 capacity frypots. The capacity is described on the serial plate that is located inside the front door on the left side.

Table of Contents

Specifications	4
Installation	5
Operation	11
Cooking Hints	13
Cleaning	13
Service	15
Parts	19
Fryer Warranty	23

Read these instructions carefully before attempting installation. Installation and initial startup should be performed by a qualified installer. Unless the installation instructions for this product are followed by a qualified service technician (a person experienced in and knowledgeable with the installation of commercial gas and/or electric cooking equipment) then the terms and conditions on the Manufacturer's Limited Warranty will be rendered void and no warranty of any kind shall apply.

SPECIFICATIONS

DIMENSIONS

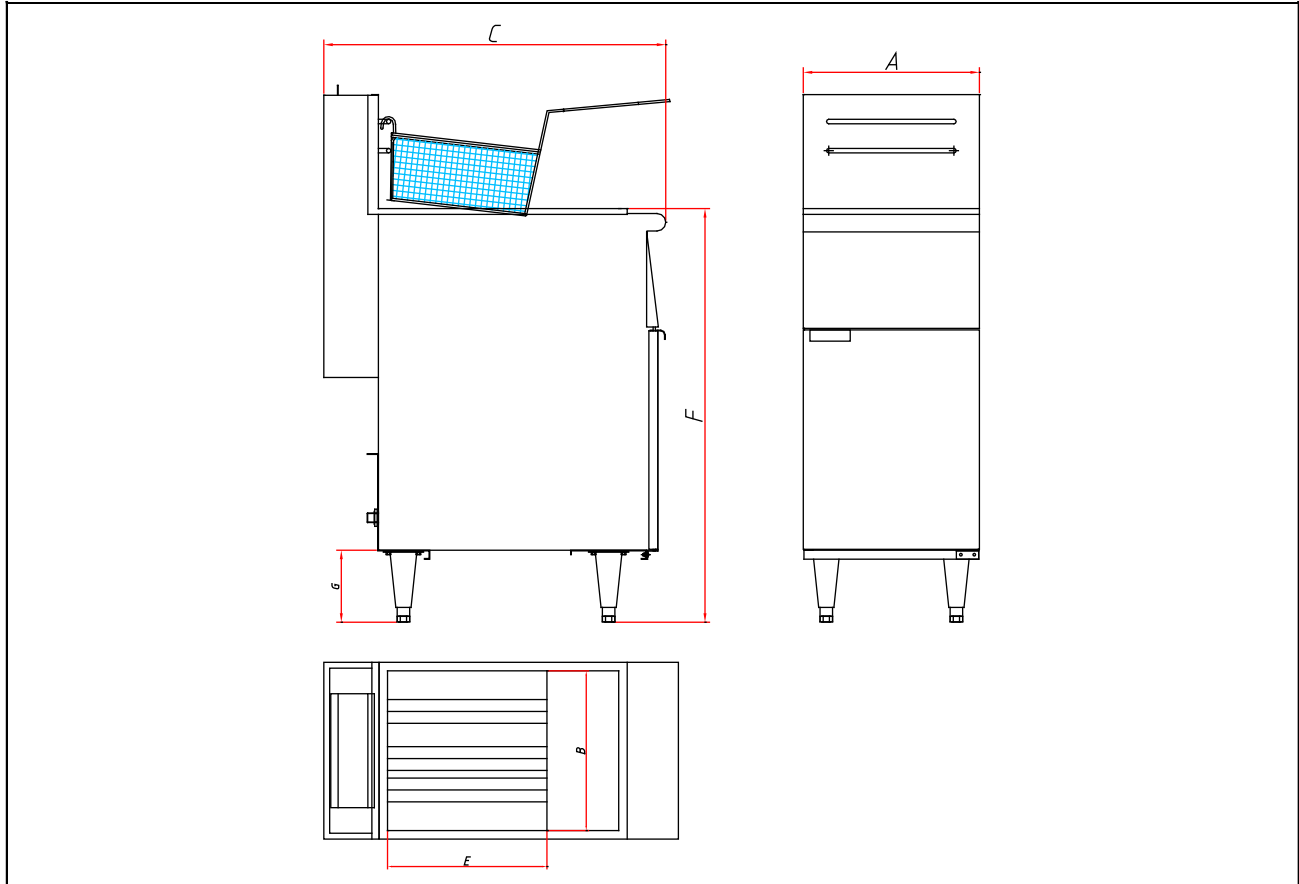

Model	Width (in)		Depth (in)		Height (in)			Gas Connection (in)		Total BTU/hr	Crated Weight (lbs)
	A	B	C	D	E	F	G	H	I		
FF300	15.5	14.0	30.3	14.0	47.2	36.2	6.0	4.2	8.0	90,000	176
FF400	15.5	14.0	30.3	14.0	47.2	36.2	6.0	4.2	8.0	120,000	192
FF518	21.0	18.0	30.3	18.0	47.2	36.2	6.0	4.2	8.0	150,000	265

GAS SUPPLY AND BURNER INFORMATION

Supply pressure should be minimum of 4" W.C. for natural gas or 10" W.C. for propane. The fryer comes with 3/4" NPT male connector on a 1/2" pipe, allowing you to connect with either 3/4" or 1/2" NPT female connector.

Model	Burners	Gas Type	Manifold Pressure	Number of heat tube	Rate Each BTUs / Hour	Total Rate BTUs / Hour	Orifice Size
FF300	Main	Natural	4" W.C.	3	30,000	90,000	#39
		Propane	10" W.C.	3	30,000	90,000	#52
FF400	Main	Natural	4" W.C.	4	30,000	120,000	#39
		Propane	10" W.C.	4	30,000	120,000	#52
FF518	Main	Natural	4" W.C.	5	30,000	150,000	#39
		Propane	10" W.C.	5	30,000	150,000	#52

* Minimum supply pressure is 4" W.C. for natural gas and 10" W.C. for propane.

** Orifice sizes are for units installed at altitudes between 0 and 2000 feet above sea level.

INSTALLATION

NOTICE

Installation must conform with local codes, or in the absence of local codes, with the *National Fuel Gas Code, ANSI Z223.1, Natural Gas Code, CAN/CGA-B149.1*, or the *Propane Installation Code, CAN/CGA-B149.2*, as applicable.

NOTICE

These installation procedures must be followed by qualified personnel or warranty will be void.

Local codes regarding installation vary greatly from one area to another. The National Fire Protection Association, Inc. states in its NFPA 96 latest edition that local codes are the "authority having jurisdiction" when it comes to installation requirements for equipment.

Step 1: Unpack

IMMEDIATELY INSPECT FOR SHIPPING DAMAGE

All containers should be examined for damage before and during unloading. The freight carrier has assumed responsibility for safe transit and delivery. If damaged equipment is received, either apparent or concealed, a claim must be made with the delivering carrier.

Apparent damage or loss must be noted on the freight bill at the time of delivery. The freight bill must then be signed by the carrier representative (Driver). If the bill is not signed, the carrier may refuse the claim. The carrier can supply the necessary forms.

A request for inspection must be made to the carrier within 15 days if there is concealed damage or loss that is not apparent until after the equipment is uncrated. The carrier should arrange an inspection. Be certain to hold all contents plus all packing material.

1. Uncrate carefully. Report any hidden damage to the freight carrier IMMEDIATELY.
2. Do not remove any tags or labels until the unit is installed and working properly.

Step 2: Install the Legs (or optional casters) and Restraints.

A set of legs or casters is packed with the fryer. Mounting fasteners are pre-mounted on the baseplates.

1. Raise fryer sufficiently to allow legs or casters to be screwed into the baseplate. For safety, "shore up" and support the fryer with an adequate blocking arrangement strong enough to support the load.
2. Screw the four legs or casters to the plate on the bottom of the fryer. When casters have been ordered, the casters having a locking-brake should be attached under the front of the fryer.
3. Lower the fryer gently. Never drop or allow the fryer to fall.
4. Use a level to make sure that the fryer is level. Each caster, or the tubular-end of each leg, can be screwed in or out to lower or raise each corner of the fryer.
5. Attach restraints as required by local codes.

NOTICE

Unit must be level to ensure maximum performance. Improper leveling may void warranty.

NOTICE

When this appliance is installed with casters, it must be installed with the casters supplied, a connector complying with either ANSI Z21.69 CSA 6.16 and a quick-disconnect device complying with ANSI Z21.41 CSA 6.9. It must also be installed with restraining means to guard against transmission of strain to the connector, as specified in the appliance manufacturer instructions.



WARNING

If disconnection of the restraint is necessary to move the appliance for cleaning, etc., reconnect it when the appliance is moved to its original installed position.



WARNING

When this appliance is installed with casters, it must be installed with the casters supplied, a connector complying with either ANSI Z21.69 or CAN/CGA-6.16 and a quick disconnect device complying with either ANSI Z21.41 or CAN1-6.9. It must also be installed with restraining means to guard against transmission of strain to the connector, as specified in the appliance manufacturer's instructions.



WARNING

All fryers must be restrained to prevent tipping in order to avoid the splashing of hot liquid. The means of restraint may be the manner of installation.

Step 3: Flue Installation

1. Unpack the flue box and flue wrap.



2. Slide the flue box over the flue and secure it with the two self-tapping screws using a 5/16" socket.



3. Slide the flue wrap over the flue.



4. Secure it with four self-tapping screws two on the back and one on each side using a 5/16" socket.



Step 4: Check Clearances and Ventilation

Select a firm, level location for your fryer. Leave clearance, whenever possible, so that access from the rear is possible to permit cleaning. If the unit is to be set on non-combustible flooring, such as a concrete slab, 3 inches minimum toe room must be provided to prevent restriction of the air opening in the bottom of the unit.

WARNING

There must be adequate clearance between fryer(s) and construction. Clearance must also be provided in front for servicing and for operation.

Minimum Clearances:

	From Combustible Construction
Sides	6
Rear	6

ALL AVANTCO FLOOR FRYERS SHALL BE INSTALLED WITH AT LEAST A 16 INCH SPACE BETWEEN THE FRYER AND SURFACE FLAMES FROM ADJACENT EQUIPMENT.

No additional side and rear clearance is required for service as the fryer is serviceable from the front.

WARNING

Improper ventilation can result in personal injury or death. Ventilation that fails to properly remove flue products can cause headaches, drowsiness, nausea, or could result in death.

Unit Must be installed under a ventilation Hood.

All units must be installed in such a manner that the flow of combustion and ventilation air is not obstructed. Provisions for adequate air supply must also be provided. Do NOT obstruct the bottom front of the unit, as combustion air enters through this area. Be sure to inspect and clean the ventilation system according to the ventilation equipment manufacturer's instructions.

Due to the variety of problems that can be caused by outside weather conditions, venting by canopies or wall fans is preferred over any type of direct venting. It is recommended that a canopy extend 6" past the appliance and the bottom edge be located 6'6" from the floor. Filters should be installed at an angle of 45° or more from the horizontal. This position prevents dripping of grease and facilitates collecting the run-off grease in a drip pan, unusually installed with a filter. A strong exhaust fan tends to create a vacuum in the room and may interfere with burner performance or may extinguish pilot flames. Fresh air openings approximately equal to the fan area will relieve such a vacuum. In case of unsatisfactory performance on any appliance, check the appliance with the exhaust fan in the "OFF" position. Do this only long enough to check equipment performance, then turn hood back on and let it run to remove any exhaust that may have accumulated during the test.

The exhaust fan should be installed at least 2 feet above the vent opening at the top of the fryer.

Make sure all ventilation meet local code requirement

This unit is not intended to be connected directly to an outside flue.

Step 5: Gas Connection

A 3/4" male NPT line for the gas connection is located near the lower right rear corner of the fryer. The serial plate (located inside the front door of the fryer) indicates the type of gas the unit is equipped to burn (natural gas or propane). The fryer should be connected **ONLY** to the type of gas for which it is equipped.

A circuit diagram is located inside the front door of the fryer.

All Avantco equipment is adjusted at the factory; however, pilot height should be checked at installation and adjusted, if necessary.

For orifice sizes and pressure regulator settings, see the chart on page 4. If the fryer is being installed at over 2,000 feet altitude and that information was not specified when ordered, contact the appropriate authorized Avantco Service Representative or the Avantco Service Department. Failure to install with proper orifice sizing will result in poor performance and may void the warranty.

If applicable, the vent line from the gas appliance pressure regulator shall be installed to the outdoors in accordance with local codes or, in the absence of local codes, with the *National Fuel Gas Code, ANSI Z223.1, Natural Gas Installation Code, CAN/CGA-B149.1*, or the *Propane Installation Code, CAN/CGA-B149.2*, as applicable.

An adequate gas supply is imperative. Undersized or low pressure lines will restrict the volume of gas necessary for satisfactory performance. A combination gas valve and pressure regulator, which is provided with each unit, is set to maintain a 4" W.C. manifold pressure for natural gas or 10.0" W.C. manifold pressure for propane gas. However, to maintain these conditions the pressure on the supply line, when all units are operating simultaneously, should not drop below 7" W.C. for natural gas or 11" W.C. for propane gas. Fluctuations of more than 25% on natural gas or 10% on propane gas will create problems and affect burner operating characteristics. A 1/8" tap to measure the manifold pressure is located on the combination gas valve, which is on the burner manifold located directly below the burners inside the cabinet.

Purge the supply line to clean out dust, dirt, or other foreign matter before connecting the line to the unit. It is recommended that an individual manual shutoff valve be installed in the gas supply line to the unit. Use pipe joint compound that is suitable for use with both natural and LP gas on all threaded connections.

CAUTION

ALL PIPE JOINTS AND CONNECTIONS MUST BE TESTED THOROUGHLY FOR GAS LEAKS. USE ONLY SOAPY WATER FOR TESTING ON ALL GASES. NEVER USE AN OPEN FLAME TO CHECK FOR GAS LEAKS. ALL CONNECTIONS MUST BE CHECKED FOR LEAKS AFTER THE UNIT HAS BEEN PUT INTO OPERATION. TEST PRESSURE SHOULD NOT EXCEED 14" W.C.

CAUTION

THIS APPLIANCE AND ITS INDIVIDUAL COMBINATION GAS VALVE MUST BE DISCONNECTED FROM THE GAS SUPPLY PIPING SYSTEM DURING ANY PRESSURE TESTING OF THAT SYSTEM AT TEST PRESSURES IN EXCESS OF 14"WC (1/2 PSIG or 3.45 kPa).

If the incoming gas pressure is in excess of 14"WC (1/2PSI, 3.45 kPa), a proper step-down regulator will be required. See PHOTO 1 for LP application

Connect the gas supply directly to the 3/4" male NPT connector located near the lower left rear corner of the fryer. When tightening the supply pipe, be sure to hold the mating connector extending from the unit securely with a wrench. This will prevent any damage or distortion to the internal piping and controls of the unit.

After connecting the gas supply, check again that the fryer is level. Use a long spirit level four ways; across the front and rear of the frypot, and along each edge.

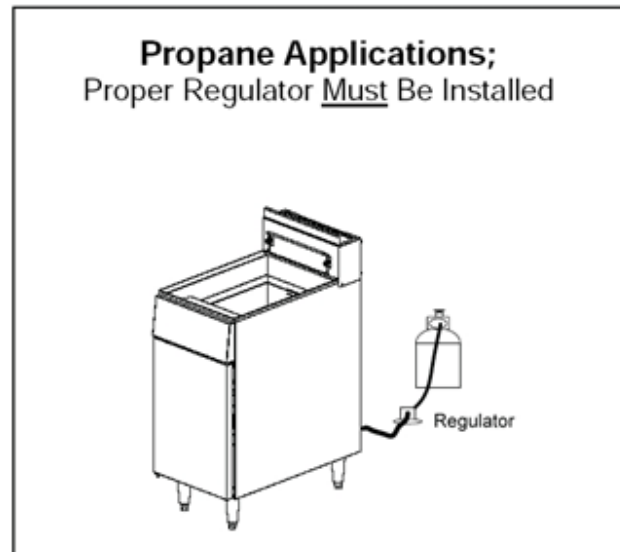

OPERATION

LIGHTING

CAUTION

IF YOU SMELL GAS DURING THE LIGHTING PROCEDURE, IMMEDIATELY SHUT OFF THE GAS SUPPLY UNTIL THE LEAK HAS BEEN CORRECTED.

Open the burner compartment door and do the following:

1. Turn thermostat to "OFF" by aligning the "OFF" with the red indicator.
2. Press down the knob of the combination gas valve, turn it counterclockwise to the "PILOT" position (shown), and continue to press the knob down.
3. While pressing the knob down, use a lit match to ignite the pilot. Continue to press the knob down for about 30 seconds. If the pilot does not stay lit when the knob is released, repeat the lighting procedure and keep the knob down longer. Adjustment of pilot flame may be necessary.
4. When the pilot stays lit, turn the knob counterclockwise to the "ON" position. Do not press down on the knob in this step.
5. Do NOT turn the thermostat "ON" until the frypot is filled with oil or solid shortening.
6. Once the frypot is filled with shortening, set the thermostat to the desired temperature

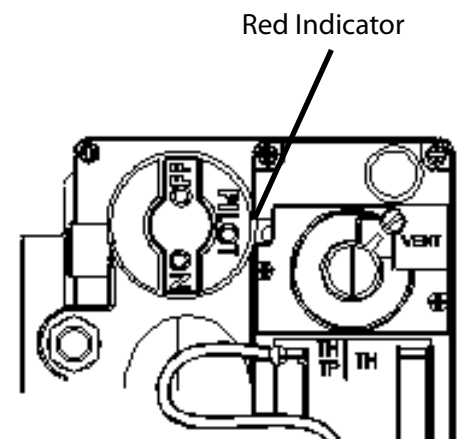

FILLING THE FRYPOT

1. Close drain valve completely before filling the frypot.
2. When the fryer is new, fill the frypot with water and clean thoroughly (see "Weekly Cleaning" on page 13) in order to remove protective coatings and any foreign matter.
3. The recommended solid shortening capacity for the frypot (35 pounds or 55 pounds) is described on the serial plate (which is located inside the front door).

4. Remove the basket support frame when filling the frypot with solid shortening.
5. When solid shortening is used, be careful not to bend, break, or twist the thin capillary wires of the sensing elements located in the frypot.
6. Pack solid shortening into the zone below the tubes, all spaces between the tubes, and at least an inch above the top of the tubes before lighting the fryer. If any air spaces are left around the heat tube surfaces when the heat is turned on, the tube surfaces will become red hot, burn the solid shortening, weaken the frypot, and

 **CAUTION**

*NEVER ATTEMPT TO MELT A SOLID BLOCK OF SHORTENING ON THE TOP OF THE HEAT TUBES.
NEVER START THE BURNERS WHEN THE FRYPOT IS EMPTY.*

7. To prevent burning or scorching the solid shortening, keep the thermostat set at the lowest temperature until all the solid shortening between and above the tubes has been melted. Additional solid shortening can then be added until the desired frying depth has been reached.
8. Replace the basket support frame over the frypot heat tubes.

SHUTDOWN PROCEDURE

Standby: Turn knob on the combination gas valve to the "PILOT" position. At this setting, only the pilot burner will remain ignited.

Complete Shutdown: Turn knob on the combination gas valve clockwise, press down on the knob and continue to turn to the "OFF" position.

RELIGHTING

 **WARNING**

In the event of a main burner ignition failure, a five minute purge period must be observed prior to re-establishing the ignition source.

1. Shut off all gas.
2. Wait five minutes.
3. Follow the "Lighting" procedure as described on page 10.

AUTOMATIC PILOT VALVE

The Automatic Pilot Valve provides an automatic safety shutoff for the fryer when the pilot flame is extinguished. When the pilot flame is burning, the valve is held open electromagnetically by the electrical current from a thermopile in the pilot flame. When the pilot flame goes out, generation of current ceases and the valve closes automatically.

HIGH LIMIT CONTROL

Avantco Floor Fryers are equipped with a secondary heat control that prevents the oil temperature from rising above 450°F. (Because of the accuracy tolerance of the sensor, the oil temperature may reach as high as 475°F.)

In the event the fryer shuts down due to this condition, the oil must be cooled to below 400°F before the pilot burner can be re-ignited. When the oil has cooled, use the "Lighting" procedure on page 9 to place the fryer back in operation. If the problem persists, contact your Avantco Service Representative or the Avantco Service Department.

COOKING HINTS

USER TIPS

- Smoking oil means that the temperature is too high, or that the oil has broken down.
- Gum in frypot denotes a need for thorough cleaning (see “Weekly Cleaning” on page 13)
- Use different oil for oily foods (mackerel, nutmeg, etc.) than for foods with water-soluble flavors (potatoes, onions, etc.).
- Taste oil for quality. Replace it regularly.
- Poor oil cannot produce good food.

CLEANING

Avantco equipment is constructed with the best quality materials and is designed to provide durable service when properly maintained. To expect the best performance, your equipment must be maintained in good condition and cleaned daily. Naturally, the frequency and extent of cleaning depends on the amount and degree of usage.

Following daily and more extensive periodic maintenance procedures will increase the life of your equipment. Climatic conditions (e.g., salt air) may result in the need for more thorough and more frequent cleaning in order to keep equipment performing at optimal levels.



WARNING: BURN HAZARD

If necessary to move the fryer for cleaning, etc., drain oil first to avoid death or serious injury.



WARNING

If disconnection of the restraint is necessary to move the appliance for cleaning, etc., reconnect it when the appliance is moved to its originally installed position.

DAILY CLEANING

1. Turn thermostat knob to “OFF” position.
2. Place hot-oil safe container under the drain and drain the frypot completely.
3. Remove the basket support frame (if applicable) and flush out any sediment remaining in the frypot with a little hot oil.
4. Wipe off the basket support frame and the inside of the frypot with a clean cloth.



CAUTION

SOME AREAS OF THE FRYPOT MAY BE HOT!

5. Close drain valve and strain the oil back into the frypot through several thicknesses of cheesecloth, or filter it back using a filter machine.

6. Replace the basket support frame (if applicable)
7. Add oil or shortening to MIN oil level mark on rear of frypot.
8. To resume cooking, turn the combination gas valve knob to "ON" position.



Tough on grease. Tough on carbon. Tempest deep fat fryer cleaner powder offers thorough boil out of encrusted grease and grime.

WEEKLY CLEANING

1. Follow steps 1 through 4 of the Daily Cleaning procedure (see previous section).
2. Close drain valve and fill frypot with a solution of warm water and boil-out compound
3. Relight the fryer and bring the solution to a gentle boil for at least five minutes.
4. Turn off main burners and let the solution stand until the gum deposits are softened and the carbon spots and burned grease spots can be rubbed off.
5. Scrub the frypot walls and heat tubes, then drain out frypot and rinse it with clean water.
6. Refill the frypot with clean water and boil again.
7. Turn off gas and drain and rinse well until clean.
8. Wipe dry with a clean cloth.
9. Refill as specified in the "Filling the Frypot" section (see page 10).

MONTHLY CLEANING

1. Perform the Weekly Cleaning procedure (see previous section).
2. Clean around burner and orifices if lint has accumulated.
3. Visually check that burner carry-over ports are unobstructed.

CLEANING STAINLESS STEEL SURFACES

To remove normal dirt, grease and product residue from stainless steel use ordinary soap and water (with or without detergent) applied with a sponge or cloth. Dry thoroughly with a clean cloth. Never use vinegar or any corrosive cleaner.

To remove grease and food splatter, or condensed vapors, that have baked on the equipment, apply cleanser to a damp cloth or sponge and rub cleanser on the metal in the direction of the polishing lines on the metal. Rubbing cleanser, as gently as possible, in the direction of the polished lines will not mar the finish of the stainless steel. NEVER RUB WITH A CIRCULAR MOTION. Soil and burnt deposits that do not respond to the above procedure can usually be removed by rubbing the surface with SCOTCH-BRITE scouring pads or STAINLESS scouring pads. DO NOT USE ORDINARY STEEL WOOL, as any particles left on the surface will rust and further spoil the appearance of the finish. NEVER USE A WIRE BRUSH, STEEL SCOURING PADS (EXCEPT STAINLESS), SCRAPER, FILE OR OTHER STEEL TOOLS. Surfaces that are marred collect dirt more rapidly and become more difficult to clean. Marring also increases the possibility of corrosive attack. Refinishing may then be required.

Darkened areas, called "heat tint," sometimes appear on stainless steel surfaces where the area has been subjected to excessive heat. These darkened areas are caused by thickening of the protective surface of the stainless steel and are not harmful. Heat tint can normally be removed by the above cleaning techniques, but tint which does not respond to that procedure calls for a vigorous scouring in the direction of the polish lines, using SCOTCH-BRITE scouring pads or a STAINLESS scouring pad in combination with a powered cleanser. Heat tint action may be lessened by not applying or by reducing, heat to equipment during slack periods.

SERVICE

FOR AUTHORIZED SERVICE TECHNICIANS ONLY!

NOTICE

Warranty will be void and the manufacturer is relieved of all liability if:

(A) Service work is performed by other than a qualified technician (see page 30 for details)

OR

(B) Other than approved Avantco replacement parts are installed.



WARNING

Adjustments and service work may be performed only by a qualified technician who is experience in, and knowledgeable with, the operation of commercial gas cooking equipment. However, to ensure your confidence, contact your Avantco Service Representative for liable service, dependable advice or other assistance, and for genuine factory parts.

All units are adjusted at the factory. In case of problems in operation at initial installation, check type of gas and manifold pressure and compare with information listed on the serial plate.

A mill voltage circuit diagram is located inside the front door of the fryer, and also on page 18.

CHECKING AND ADJUSTING MAIN BURNERS

The main burners should burn with a steady blue flame, and the inner cone of the flame from each port should be about 3/4" long. The flame from each main burner should enter each heat tube without touching the front of the frypot or the sides, top, or bottom of each tube.

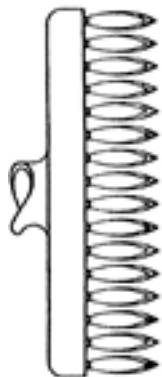

Yellow Tips
(too little air or too much gas)

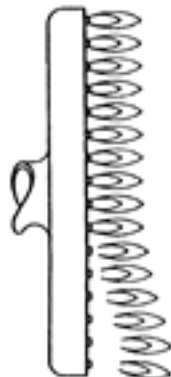

Blowing or Lifting Tips
(too much air)

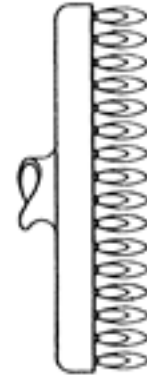

Normal Flame

CHECKING AND ADJUSTING PRESSURE REGULATOR

The combination gas valve (includes pressure regulator) is factory set at 4" W.C. for natural gas and 10" W.C. for propane gas. To check the manifold pressure, do the following:

1. Turn thermostat "OFF" and combination gas valve knob to the "PILOT" setting.
2. Remove pressure tap plug from burner manifold located directly below the burners in the cabinet.
3. Install a fitting appropriate to connect a manometer.
4. Turn combination gas valve to "ON" position and thermostat to "ON." The burners will ignite. Be certain that sufficient oil is covering the tubes.
5. With burners on, read manometer.
6. If the manometer does not read 4" W.C. for natural gas, or 10" W.C. for propane gas, adjust regulator.
7. Remove regulator adjustment screw cap (see diagram on page 15).
8. With small screwdriver rotate adjustment screw "CLOCKWISE" to increase or "COUNTERCLOCKWISE" to decrease pressure. Be sure to adjust with burners "ON."
9. Turn thermostat "OFF" and set combination gas valve knob to "PILOT" position.
10. Remove manometer and replace pressure tap plug.
11. Replace adjustment screw cap.

CHECKING AND ADJUSTING CALIBRATION OF THERMOSTAT

All thermostat controls are carefully calibrated at the factory (i.e., the dial is properly set to control appliance temperatures accurately). Only a qualified appliance service technician should perform this adjustment.

1. To check appliance temperatures, use a thermocouple-type temperature test instrument or reliable thermometer. Place the thermocouple of test instrument or thermometer in the center of the frypot.
2. Turn the control dial to the temperature setting requiring the greatest accuracy. Allow enough time for temperature to stabilize, or until several temperature readings are identical.
3. Recalibrate if setting and actual temperature differ by more than 10°F.
4. Remove dial from dial shaft "B." Be careful that dial shaft does not rotate in either direction (which would change the dial setting).
5. Hold dial shaft "B" steady and with a screwdriver turn calibration screw "A" clockwise to decrease the temperature, or counterclockwise to increase the temperature.
6. Replace dial. Let the appliance operate until the temperature has stabilized before a final check is made to determine whether or not the calibration has been corrected.
7. Once correct, seal the calibration screw with glyptol.

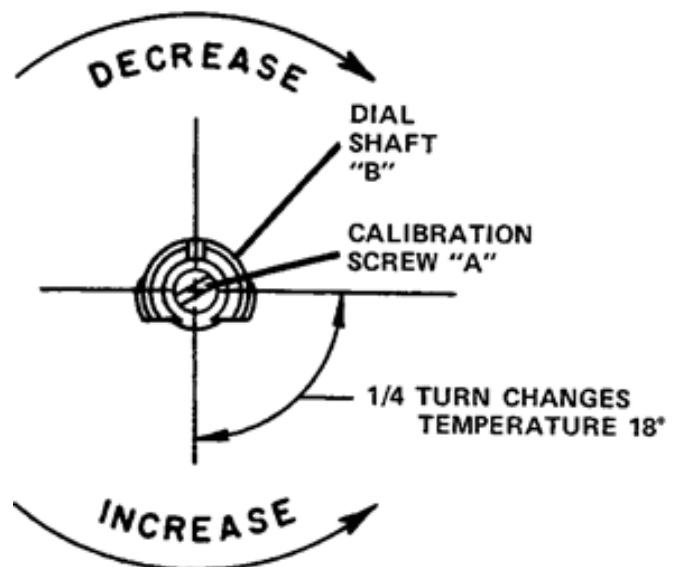

CHECKING AND ADJUSTING AUTO SAFETY PILOT

The pilot flame should surround the thermopile for 1/2". It must be large and sharp enough to cause the thermopile to glow a dull red, or sufficient to hold the safety valve open.

1. Remove pilot adjustment cap.

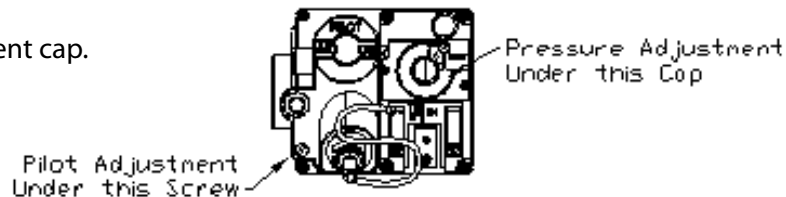

2. Adjust pilot key to provide properly sized flame as shown in diagram B. Diagram A shows improperly adjusted pilot.
3. Release pilot adjustment cap.



TROUBLESHOOTING

Problem	Likely Cause
Burners do not come on	Gas supply to unit off. Combination gas valve is in "OFF" or "PILOT" position. Pilot not ignited. Thermostat not "ON."
Pilot will not stay ignited	Combination gas valve is in "OFF" position. Pilot gas not adjusted properly. Gas supply to unit off. Bad thermopile. Dirty thermopile connections at combination gas valve or high limit. Clogged orifice. Draft condition. Air in gas line. Improper ventilation system.
Pilot produces carbon deposits	Unit connected to wrong gas supply. Pressure not adjusted correctly. Pilot gas not adjusted correctly.
Burners produce carbon deposits	Wrong size orifices. Connected to wrong gas supply. Pressure not adjusted correctly. Flue obstructed.

NOTE: Vibrations or shock caused by shaking or pounding baskets on top surface or by slamming door may cause Hi-Limit Control Switch to open. If this condition persists, additional cushioning may be added to the rubber grommets supporting this control to absorb these shocks.

WIRING DIAGRAM

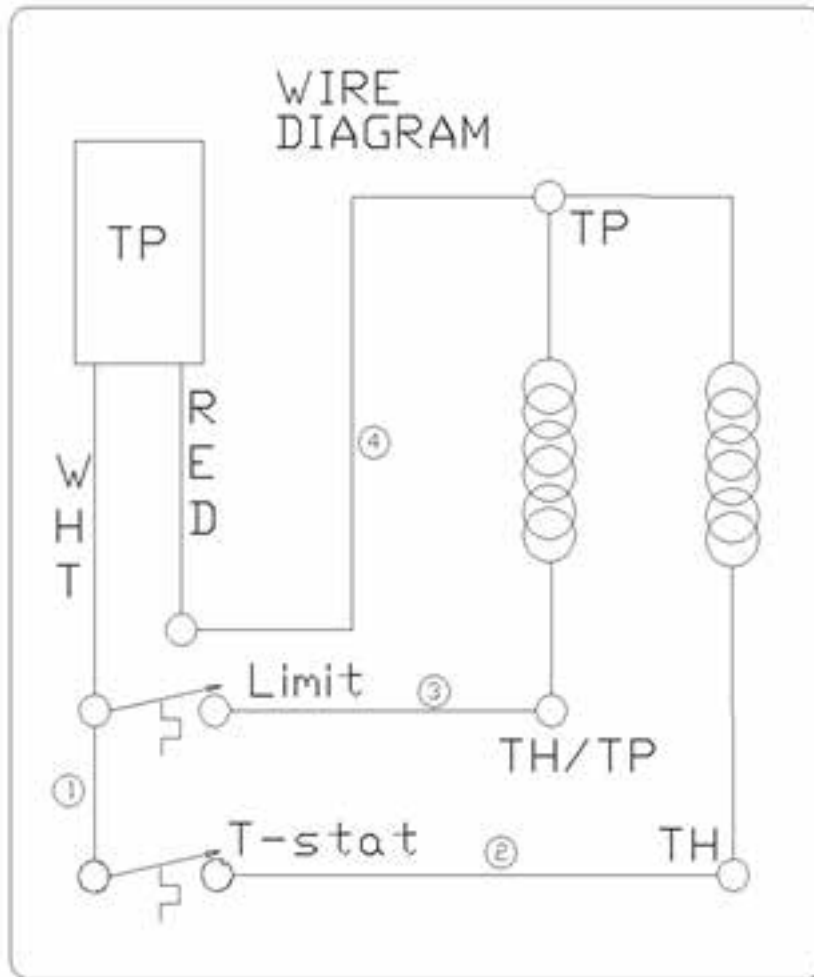

PARTS

NOTICE

INSTALLATION OF OTHER THAN GENUINE AVANTCO PARTS WILL VOID THE WARRANTY ON THIS EQUIPMENT

The serial plate is located inside the front door on the left side.

Replacement parts may be ordered either through a Entree Authorized Parts Distributor or a Entree Authorized Service Agency.

When ordering parts, please supply the Model Number, Serial Number, Part Number, and Description.

Index of Part Diagrams	
Page Number	Description
20 G	Gas Parts for 3, 4 and 5 tube fryer
21 T	Tank Parts for 3, 4 and 5 tube fryer
22	Other Parts (Legs, Casters, Baskets, Doors, Magnet)

Gas Parts for Fryer (3 tube shown)

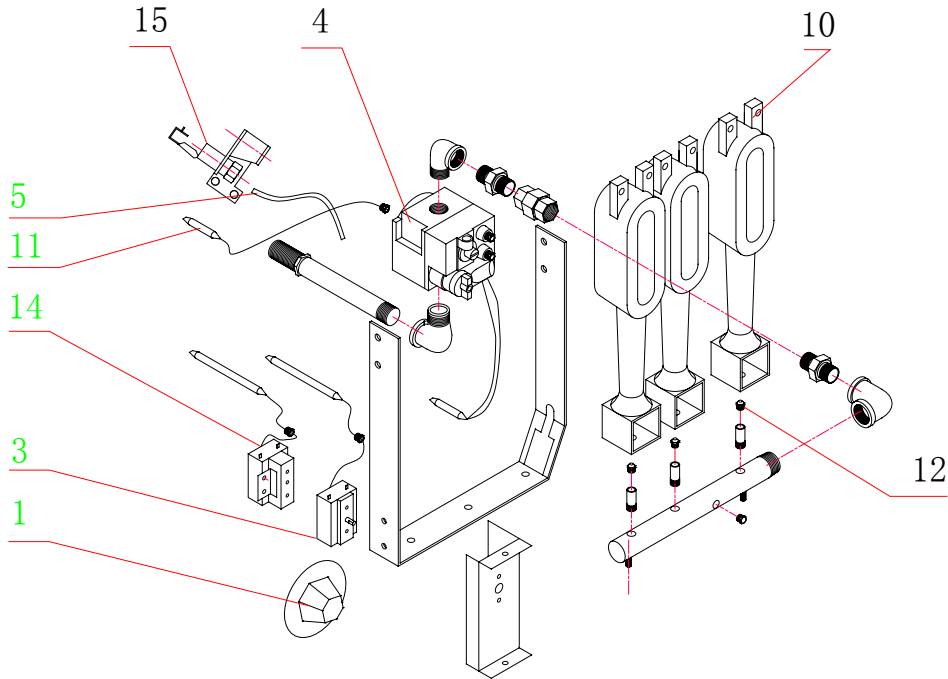

Key	Part Number	Qty	Description
1	400045	1	Knob, thermostat
3	400044	1	Thermostat Fryer, regulating 200-400
4	400042	1	Combination Valve (Nat)
4	400146	1	Combination valve (LP)
5	400070	1	Tubing, 1/4" fryer pilot
10	300031	ea	Burner, Fryer
11	400043	1	Safety thermopile 18"
12	300034	ea	Orifice # 39 (Nat) (as part of kit 266003)
12	300035	ea	Orifice # 52 (LP) (as part of kit 266002)
14	400046	1	Thermostat, High limit 450F
15	400047	1	Pilot 3- way

Tank Parts (3 tube shown)

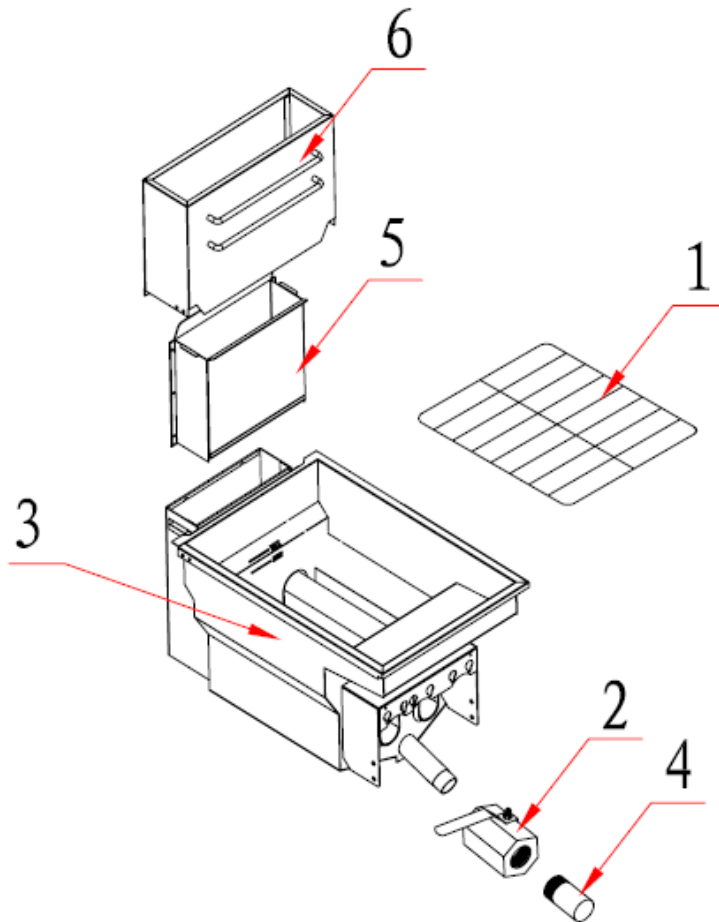

Key	Part Number	Qty	Description
1	400037	1	Screen, crumb, 3 and 4 tube fryer
*	400058	1	Screen, crumb, 5 tube fryer
2	400036	1	Valve, Ball
3	C200016	1	Tank, 3 tube fryer (excluding flue)
*	C200017	1	Tank, 4 tube fryer (excluding flue)
*	C400056	1	Tank, 5 tube fryer (excluding flue)
4	400071	1	Drain, extension
5	400075	1	Flue, top, removable, 3 tube fryer
*	400076	1	Flue, top, removable, 4 tube fryer
*	400077	1	Flue, top, removable, 5 tube fryer
6	400078	1	Flue, wrap, top, removable, 3 and 4 tube fryer
*	400079	1	Flue, wrap, top, removable, 5 tube fryer
*not shown			

Leg Parts

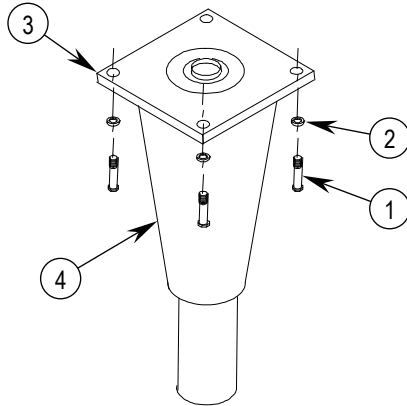

Key	Part Number	Description
1	400108	1/4-20 Bolt 3/4" Long
2	400111	1/4" Lock Washer
3	400000	Leg, 6"

* Not shown on drawing.

Caster Parts



400106



400107

#	Part Number	Description
1	400108	1/4-20 Bolt 3/4" Long
2	400111	1/4" Lock washer
3	400106	Caster, 4", swivel with brake
4	400107	Caster 4", rigid

*not shown on drawing.

FRYER WARRANTY

NON-TRANSFERRABLE

All new Avantco Floor Fryers are warranted to be free from defects in material and workmanship under normal use and service for a period of (1) year from the date of purchase, and for 30 days after purchase for food trucks. Proof of purchase required. This is limited to the repair and replacement, including labor charges, of defective parts and or assemblies. Labor, travel and mileage covered for the first year include straight time labor charges and travel charges within 100 miles, roundtrip.

1. This warranty is limited to original installation of new Avantco Floor Fryers for the original user in the United States or Canada. This warranty is not transferable.
2. This warranty does not apply to any equipment that has not been installed in accordance with the directions published in the appropriate installation and operation manuals.
3. Avantco will bear no responsibility or liability for any equipment which has been mishandled, abused, misapplied, misused, subjected to harsh chemical action, or external causes such as gas fluctuations, field modified without the approval of Avantco or by unauthorized personnel, improperly installed or maintained, equipment damaged by flood, fire or other acts of God, or which have altered or missing serial numbers.
4. This warranty applies only to defects in parts and workmanship in equipment and not damage incurred in shipping or handling.
5. If the equipment has been changed, altered, modified or repaired with parts not authorized or by a nonqualified Avantco Service Technician, then Avantco shall not be responsible for warranty claim.
6. Adjustments such as calibrations, leveling, tightening of fasteners or utility connections normally associated with original installation are the responsibility of installer and not that of Avantco. Regular maintenance and cleaning, shall be the responsibility of the customer.
7. Avantco will bear normal labor charges incurred in the repair or replacement of a warranted piece of equipment within 50 miles of an authorized service agent. Overtime, premium labor charges and travel charges in excess of 100 miles round trip will not be covered by Avantco and will be the responsibility of the person or firm requesting the service.
8. Original purchased replacement parts will be warranted for 90 days from the parts invoice date. This warranty is for parts cost only, does not include freight or labor charges.
9. This warranty provides the exclusive remedy against Avantco relating to all Avantco, whether in contract or in tort or under any other legal theory, and whether arising out of warranties, representations, instructions, installations or defects from any cause. Avantco shall not be liable, under any legal theory, for loss of use, revenue or profit, or for substitute use or performance, or for incidental, indirect, or special or consequential damages or for any other loss of cost of similar type. The laws of some jurisdictions limit or do not allow the disclaimer of consequential damages. If the laws of such a jurisdiction apply to any claim by or against Avantco, NO limitations and disclaimers contained here shall be the greatest extent permitted by law.

10. The liability of Avantco is limited to the repair or replacement of any part found to be defective.
11. THIS WARRANTY AND THE LIABILITIES SET FORTH HEREIN ARE EXCLUSIVE AND IN LIEU OF ALL OF THEIR LIABILITIES AND WARRANTIES, EXPRESS OR IMPLIED, INCLUDING BUT NOT LIMITED TO, IMPLIED WARRANTIES OF MERCHANTABILITY AND FITNESS FOR PARTICULAR PURPOSE AND CONSTITUTES THE ONLY WARRANTY OF AVANTCO WITH RESPECT TO THE PRODUCT(S). AVANTCO LIABILITY ON ANY CLAIM, INCLUDING BUT NOT LIMITED TO NEGLIGENCE, SHALL NOT EXCEED THE PRICE OF THE EQUIPMENT THAT GIVES RISE TO THE CLAIM.
12. If required by Avantco customer shall return to Avantco for examination any failed product or part to confirm that the part has failed as a result of material or workmanship.
13. The foregoing warranty is the Avantco Floor Fryer warranty of Avantco. Avantco neither assumes nor authorizes any other person, purporting to act on its behalf, to modify or to change this warranty, or any other warranty or liability concerning the goods.

** This Warranty does not apply to, and Avantco is not responsible for, any warranty claims made on products sold or used outside of the United States or Canada.

Customer Service (570) 497-5477 - Fax (888) 388-6017



Conforms to ANSI
STD Z83.11b
Certified to CSA
STD 1.8b
Conforms to
NSF/ANSI STD 4



GAS FRYER ELEVATION CHART

Gas Type	Size at Sea Level	2,000'	3,000''	4,000'	5,000'	6,000'	7,000'	8,000'	9,000'	10,000'
Natural	39	40	41	41	42	42	43	43	44	44
LP	52	52	53	53	53	53	53	54	54	54

FRYER WARRANTY

NON-TRANSFERRABLE

All new Avantco Floor Fryers are warranted to be free from defects in material and workmanship under normal use and service for a period of (1) year from the date of purchase, and for 30 days after purchase for food trucks. Proof of purchase required. This is limited to the repair and replacement, including labor charges, of defective parts and or assemblies. Labor, travel and mileage covered for the first year include straight time labor charges and travel charges within 100 miles, roundtrip.

1. This warranty is limited to original installation of new Avantco Floor Fryers for the original user in the United States or Canada. This warranty is not transferable.
2. This warranty does not apply to any equipment that has not been installed in accordance with the directions published in the appropriate installation and operation manuals.
3. Avantco will bear no responsibility or liability for any equipment which has been mishandled, abused, misapplied, misused, subjected to harsh chemical action, or external causes such as gas fluctuations, field modified without the approval of Avantco or by unauthorized personnel, improperly installed or maintained, equipment damaged by flood, fire or other acts of God, or which have altered or missing serial numbers.
4. This warranty applies only to defects in parts and workmanship in equipment and not damage incurred in shipping or handling.
5. If the equipment has been changed, altered, modified or repaired with parts not authorized or by a nonqualified Avantco Service Technician, then Avantco shall not be responsible for warranty claim.
6. Adjustments such as calibrations, leveling, tightening of fasteners or utility connections normally associated with original installation are the responsibility of installer and not that of Avantco. Regular maintenance and cleaning, shall be the responsibility of the customer.
7. Avantco will bear normal labor charges incurred in the repair or replacement of a warranted piece of equipment within 50 miles of an authorized service agent. Overtime, premium labor charges and travel charges in excess of 100 miles round trip will not be covered by Avantco and will be the responsibility of the person or firm requesting the service.
8. Original purchased replacement parts will be warranted for 90 days from the parts invoice date. This warranty is for parts cost only, does not include freight or labor charges.
9. This warranty provides the exclusive remedy against Avantco relating to all Avantco, whether in contract or in tort or under any other legal theory, and whether arising out of warranties, representations, instructions, installations or defects from any cause. Avantco shall not be liable, under any legal theory, for loss of use, revenue or profit, or for substitute use or performance, or for incidental, indirect, or special or consequential damages or for any other loss of cost of similar type. The laws of some jurisdictions limit or do not allow the disclaimer of consequential damages. If the laws of such a jurisdiction apply to any claim by or against Avantco, NO limitations and disclaimers contained here shall be the greatest extent permitted by law.

10. The liability of Avantco is limited to the repair or replacement of any part found to be defective.
11. THIS WARRANTY AND THE LIABILITIES SET FORTH HEREIN ARE EXCLUSIVE AND IN LIEU OF ALL OF THEIR LIABILITIES AND WARRANTIES, EXPRESS OR IMPLIED, INCLUDING BUT NOT LIMITED TO, IMPLIED WARRANTIES OF MERCHANTABILITY AND FITNESS FOR PARTICULAR PURPOSE AND CONSTITUTES THE ONLY WARRANTY OF AVANTCO WITH RESPECT TO THE PRODUCT(S). AVANTCO LIABILITY ON ANY CLAIM, INCLUDING BUT NOT LIMITED TO NEGLIGENCE, SHALL NOT EXCEED THE PRICE OF THE EQUIPMENT THAT GIVES RISE TO THE CLAIM.
12. If required by Avantco customer shall return to Avantco for examination any failed product or part to confirm that the part has failed as a result of material or workmanship.
13. The foregoing warranty is the Avantco Floor Fryer warranty of Avantco. Avantco neither assumes nor authorizes any other person, purporting to act on its behalf, to modify or to change this warranty, or any other warranty or liability concerning the goods.

** This Warranty does not apply to, and Avantco is not responsible for, any warranty claims made on products sold or used outside of the United States or Canada.

Customer Service (570) 497-5477 - Fax (888) 388-6017



Conforms to ANSI
STD Z83.11b
Certified to CSA
STD 1.8b
Conforms to
NSF/ANSI STD 4